

SECTION A-A

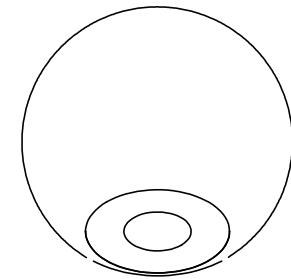
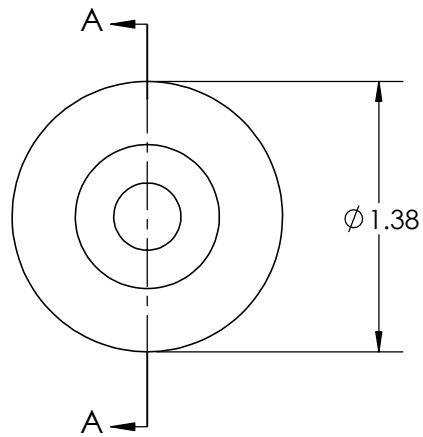

REV	BY	DATE	COMMENT	DRAWN	JMR			
0	JMR	04/18/08	RELEASE DATE	APPROVED	LQR		PART NAME	
				DATE	04/18/08	COMMENTS MIN. TORQUE N/A in.-lbs.		
				DIMENSIONS ARE IN INCHES TOLERANCES FRACTIONAL $\pm$ TWO PLACE DECIMAL $\pm 0.03$ THREE PLACE DECIMAL $\pm 0.010$ UNLESS OTHERWISE NOTED				
<b>PROPRIETARY AND CONFIDENTIAL</b> THE INFORMATION CONTAINED IN THIS DRAWING IS THE SOLE PROPERTY OF INNOVATIVE COMPONENTS. ANY REPRODUCTION IN PART OR AS A WHOLE WITHOUT THE WRITTEN PERMISSION OF INNOVATIVE COMPONENTS IS PROHIBITED.				KNOB MATERIAL Polypropylene, Black		PART NUMBER <b>B3S MASTER</b>		
				KNOB FINISH			INSERT MATERIAL	DRAWING NUMBER <b>K-B3</b>
				INSERT PART NUMBER			INSERT FINISH	
						SHEET 1 OF 1		